

# DUROTANKER

2,000L SELF BUNDED

**airpowered**

We'll keep you running on air



Size	Safe Fill (L)	Weight 9kg)	Length (mm)	Width (mm)	Height (mm)
2,000L	2,000	1,200	4,700	2,000	1,650

## Features:

- Designed and manufactured in Australia to Australian Standards
- Self bunded (double wall)
- Dual Axle, low profile design with low centre of gravity
- Spare Wheel, mount to rear of trailer
- Lockable pump cabinet with gus struts
- Calibrated dipstick with safe fill level
- Safety signage for Australian regulations
- Rubber Torison Suspension - which is maintenance free
- 5x new 16" Wheel
- Mechanical Brakes with hand brake
- 4.5kg Fire Extinguisher and 30L Spill kit
- Side toolbox and water tank
- Diesel Driven Pumps
- 10m, Heavy Duty Retractable Hose Reel, Wiggins Nozzle
- Emergency Stop, Battery Isolator, Wheel Chocks, Wheel Nut Indicators and Reflective Mine Tape
- Auto Shutoff Nozzle



**HIRE SALES SERVICE**  
[airpoweredservices.com.au](http://airpoweredservices.com.au)

ABN: 63 070 186 159 ACN: 070 186 159

**1800 AIR POW**

- Melbourne
- Sydney
- Brisbane
- Perth



1 2 3 4 5 6 7 8 9 10

A

B

C

D

E

F

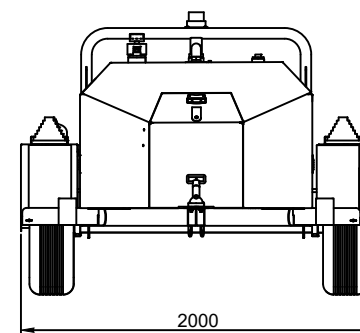
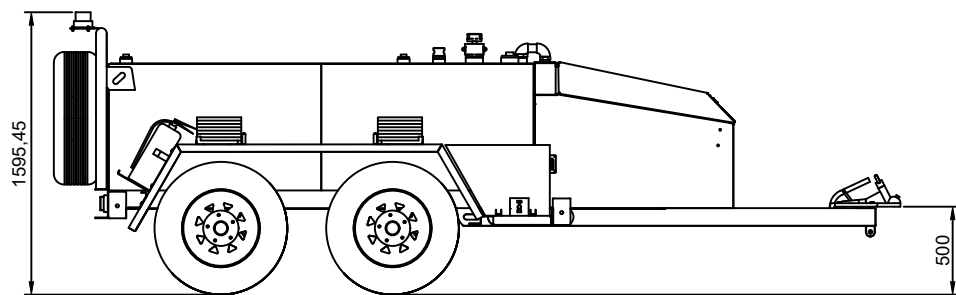
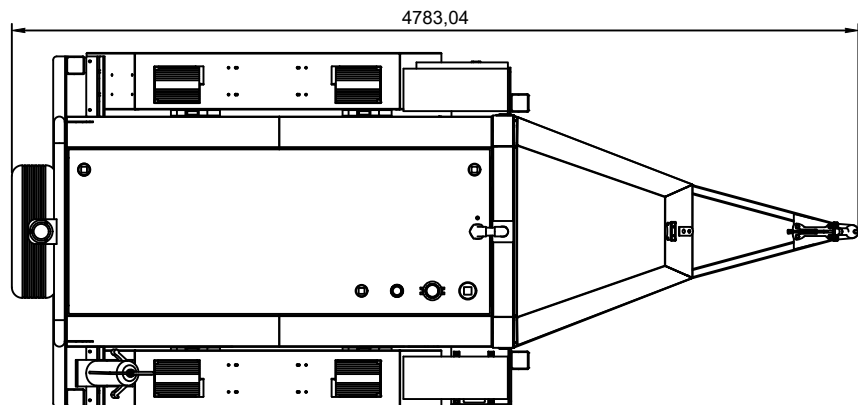

REV	DATE	DETAILS	BY/APPD

**GENERAL NOTES**  
 ALL DIMENSIONS ARE IN MILLIMETERS (mm) U.N.O  
 GENERAL TOLERANCE U.N.O  
 X ±0,05  
 X.X ±0,1  
 X.XX ±0,05  
 Angular ±0,25°  
 REMOVE ALL SHARP EDGES AND BURRS  
 PAINTING MANUFACTURER IN ACCORDANCE  
 MATERIAL GR250



		TITLE LAYOUTS	
DRN: MWH DATE: 13.07.2023 CHK:	SHEET A3	DWG NO:	DT020 PAGE 02 OF 00

1 2 3 4 5 6 7 8 9 10